

男子個人戦 (1)

A

B

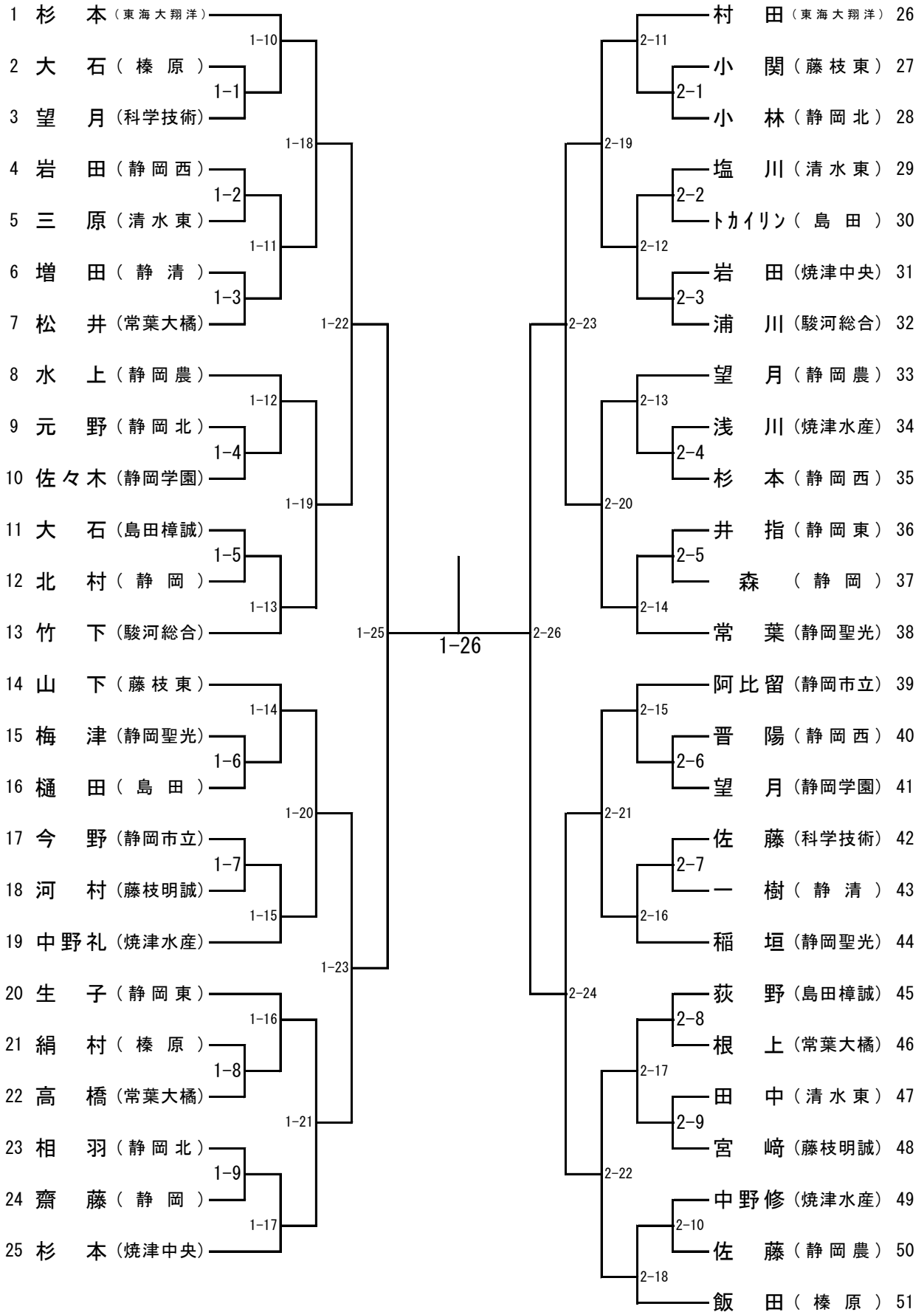

男子個人戦 (2)

C

D

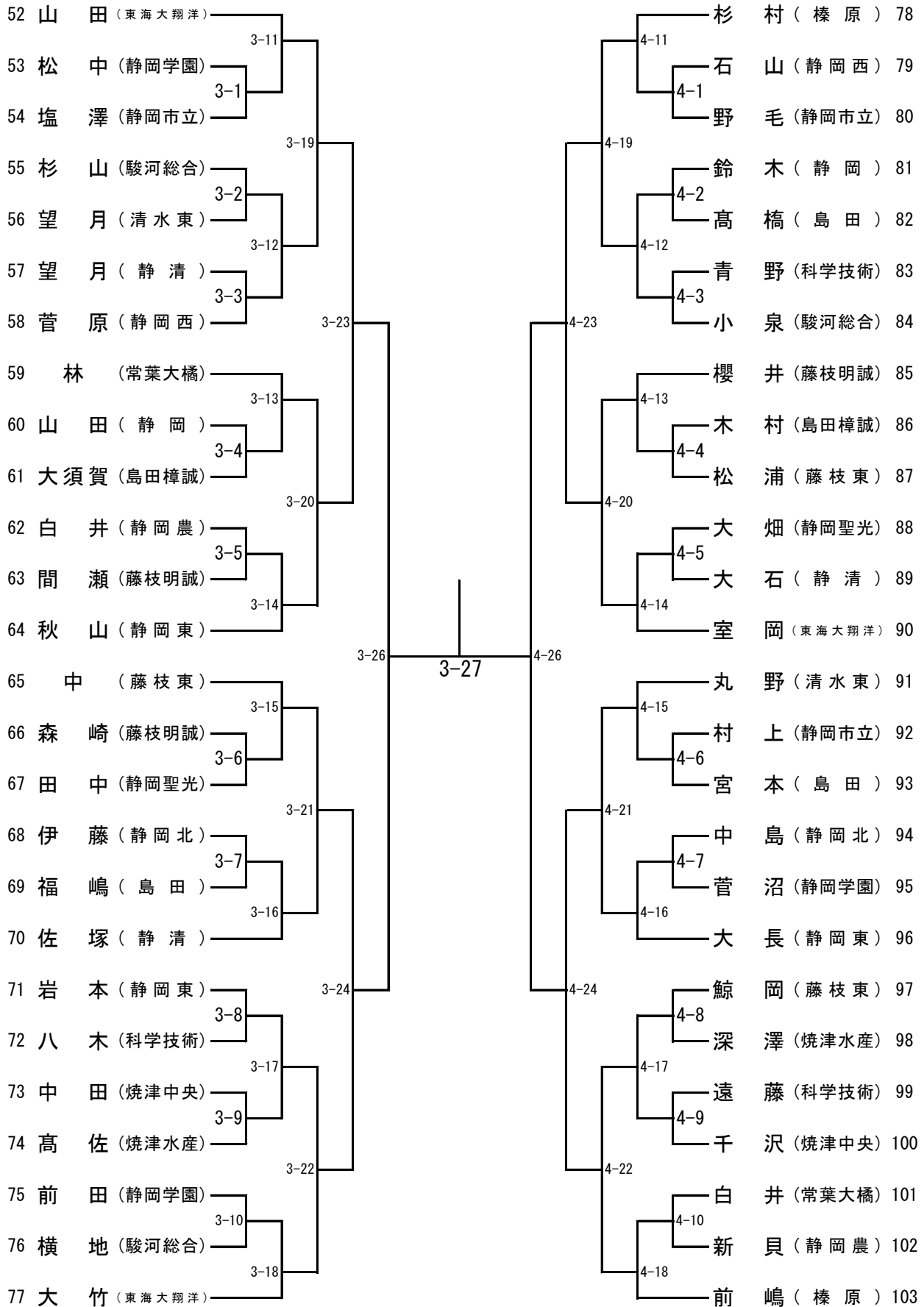

男子個人戦 順位決定戦

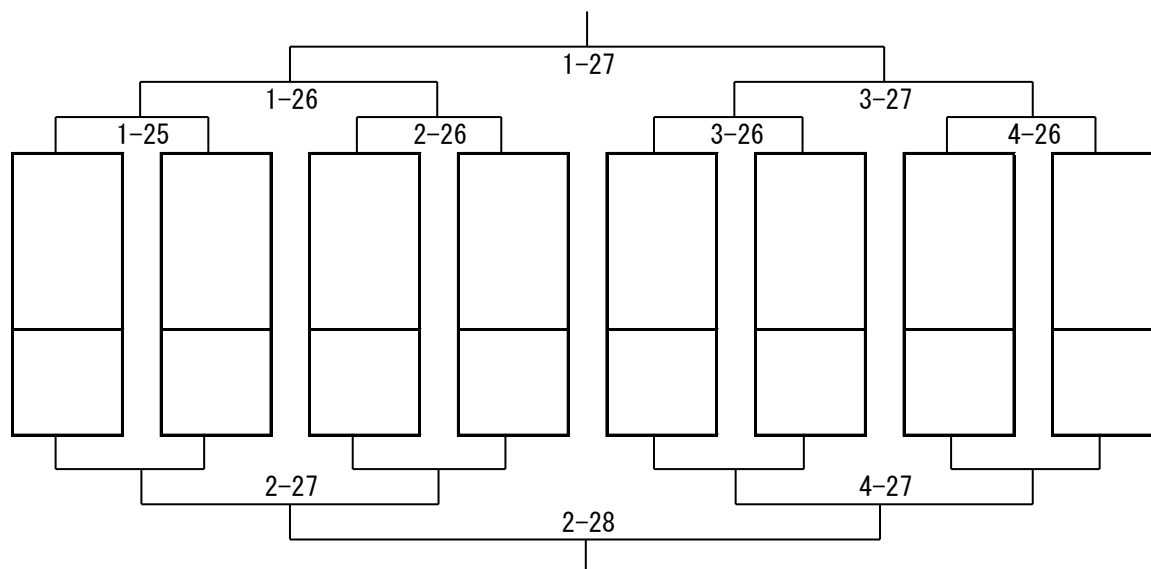

7・8位決定戦

5・6位決定戦

3位決定戦

決勝

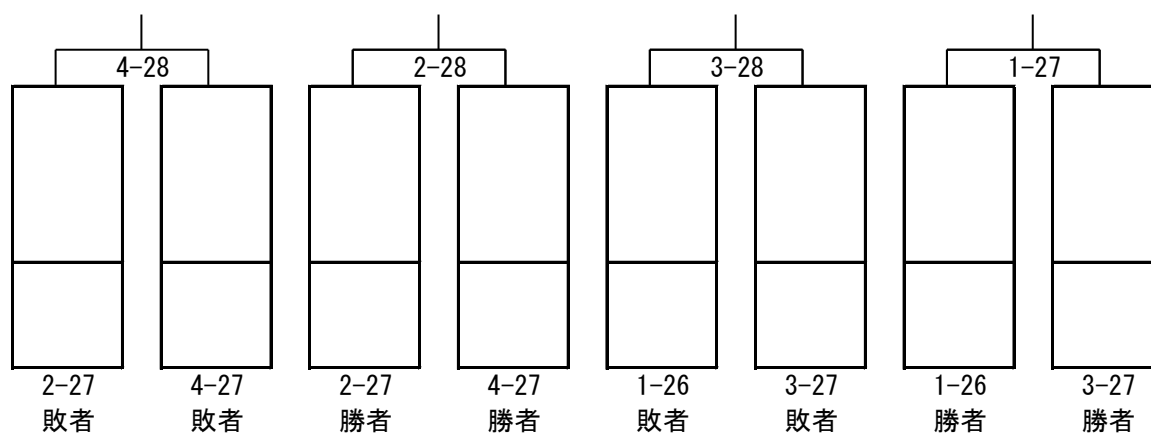

9～12位・13～16位振り分け戦（試合後、放送で抽選の呼び出しをします）

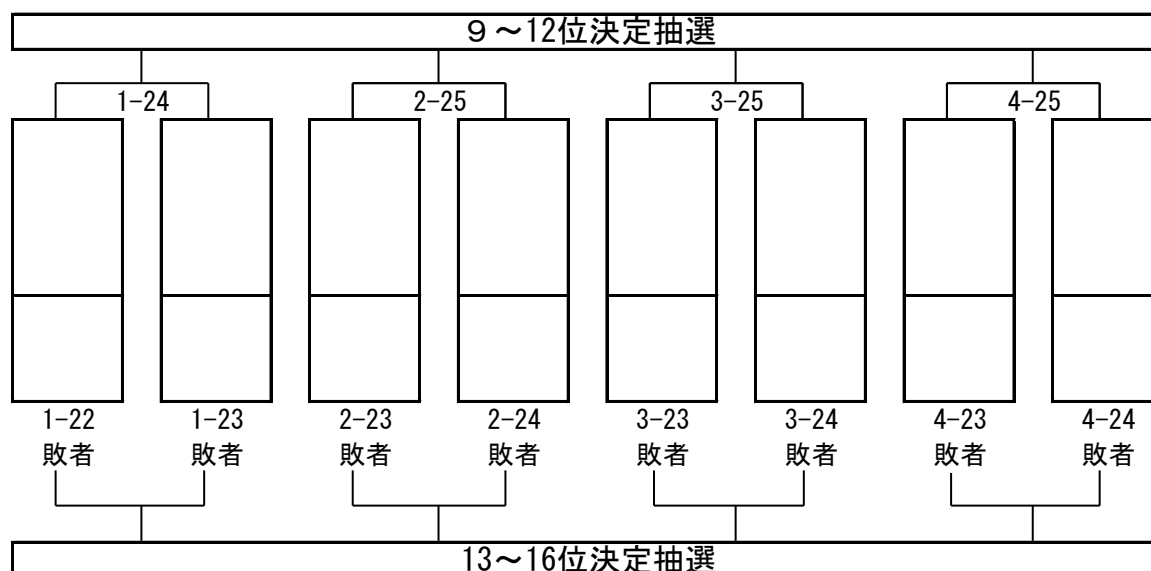

女子個人戦 (1)

A

B

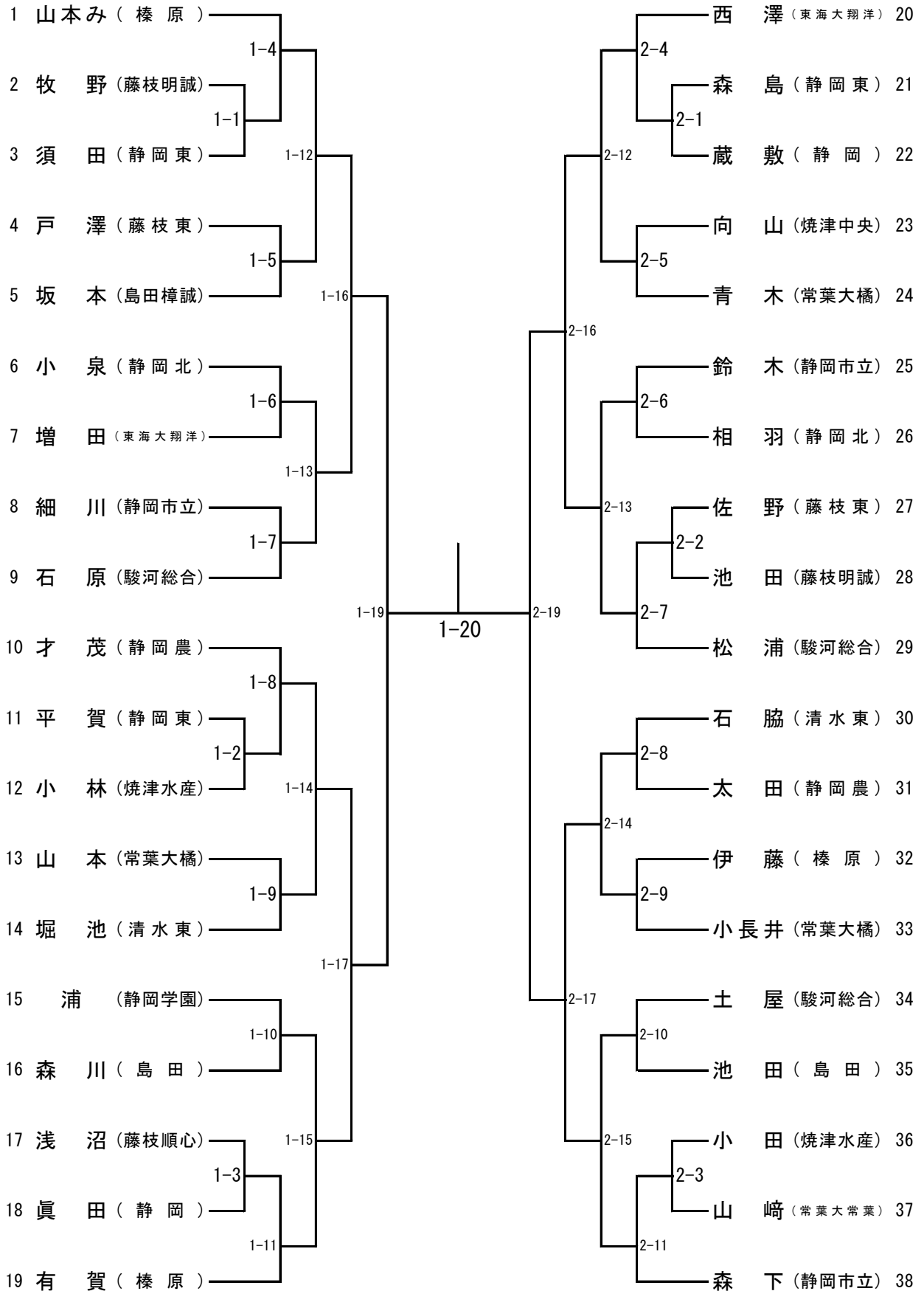

女子個人戦 (2)

C

D

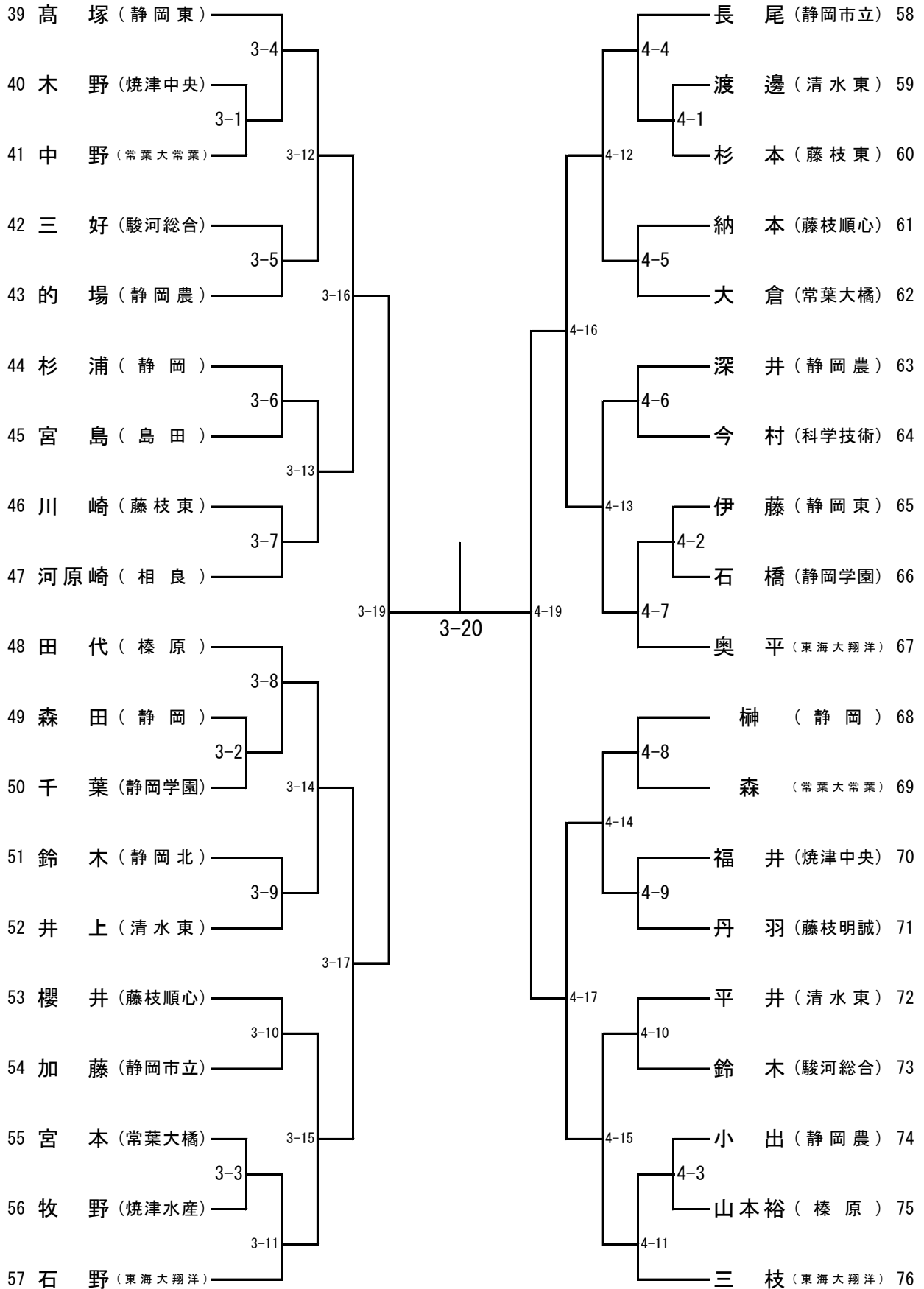

女子個人戦 順位決定戦

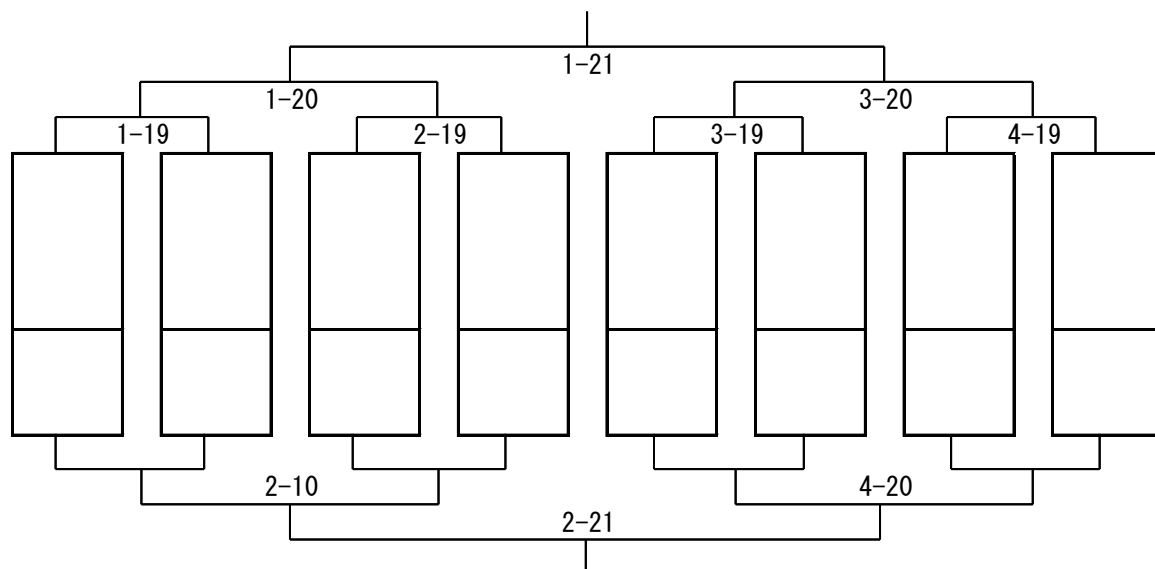

7・8位決定戦

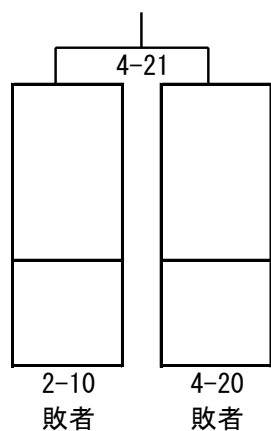

5・6位決定戦

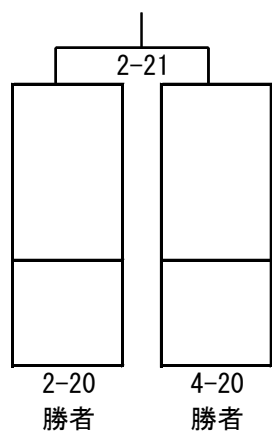

3位決定戦

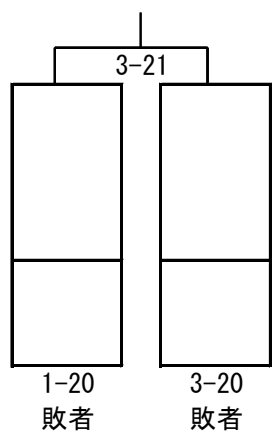

決勝

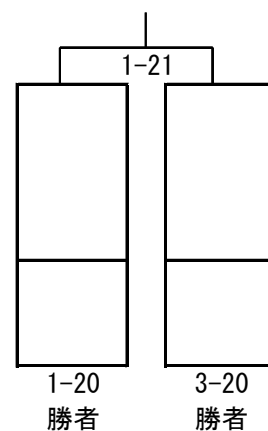

9～12位・13～16位振り分け戦（試合後、放送で抽選の呼び出しをします）

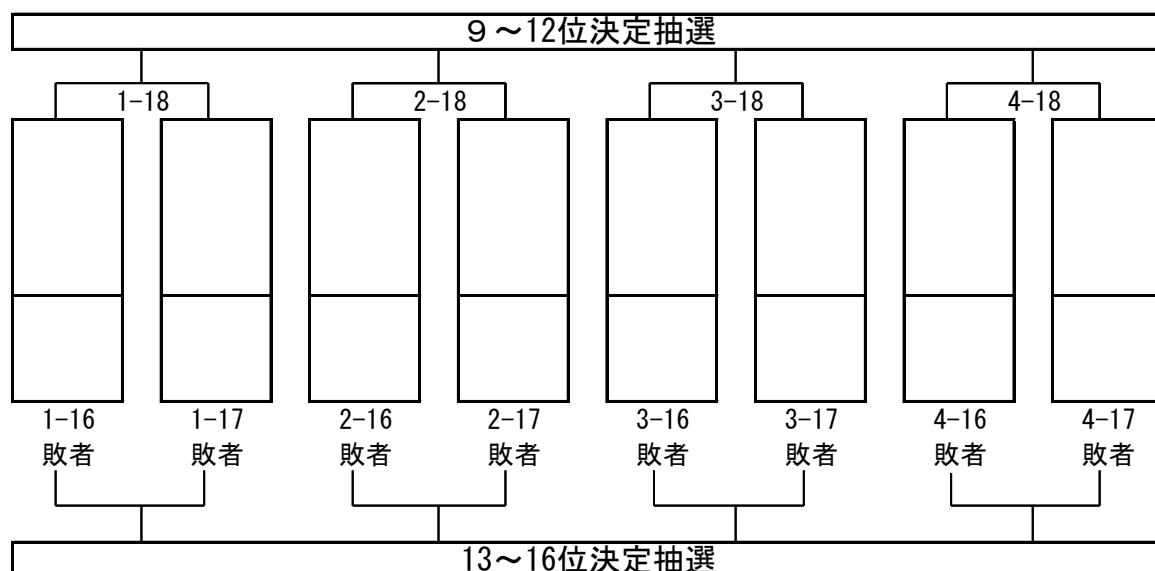

令和4年度 静岡県高校総体剣道競技中部地区予選 (男子団体)

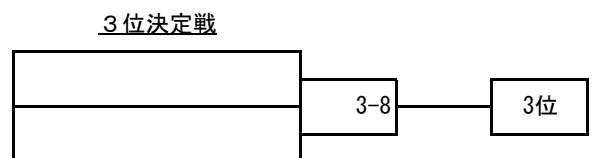
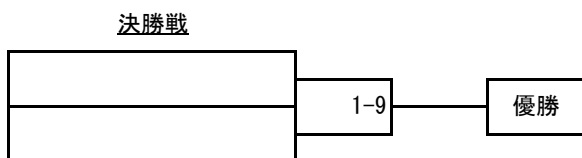
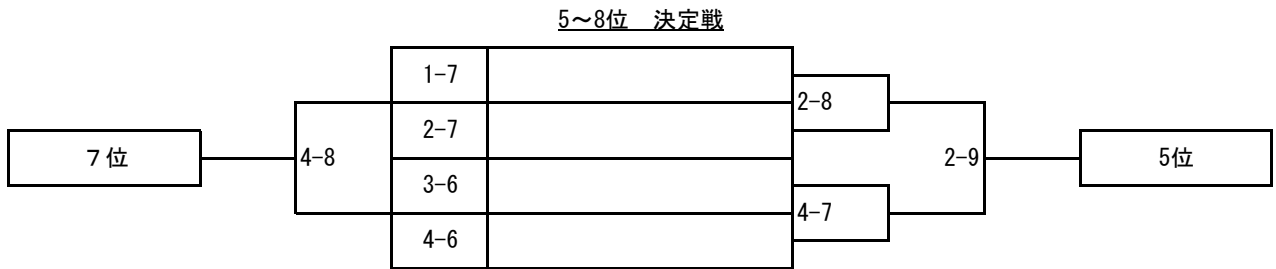
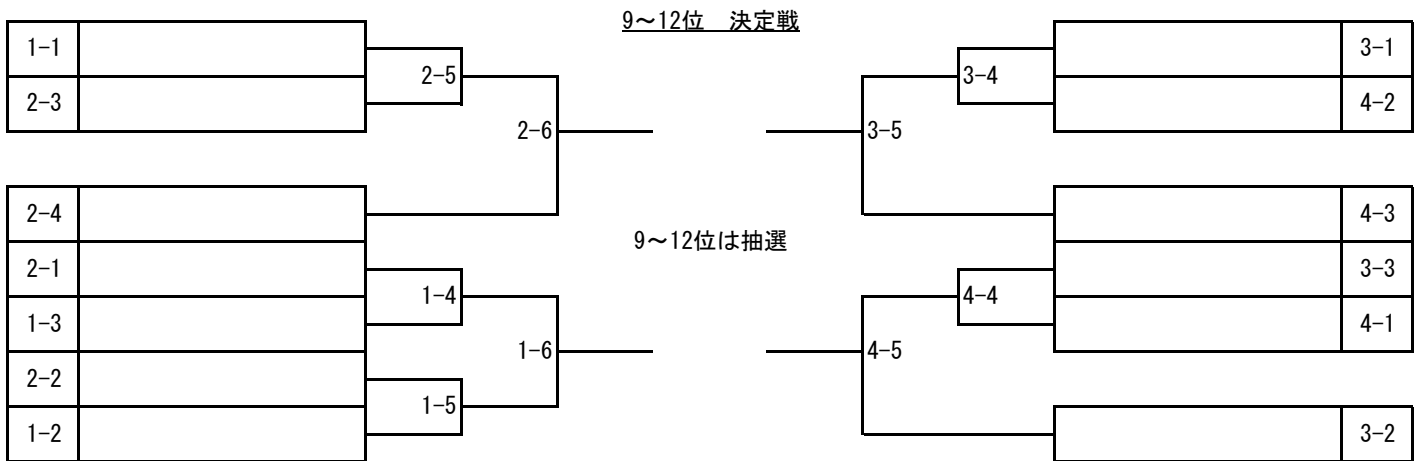
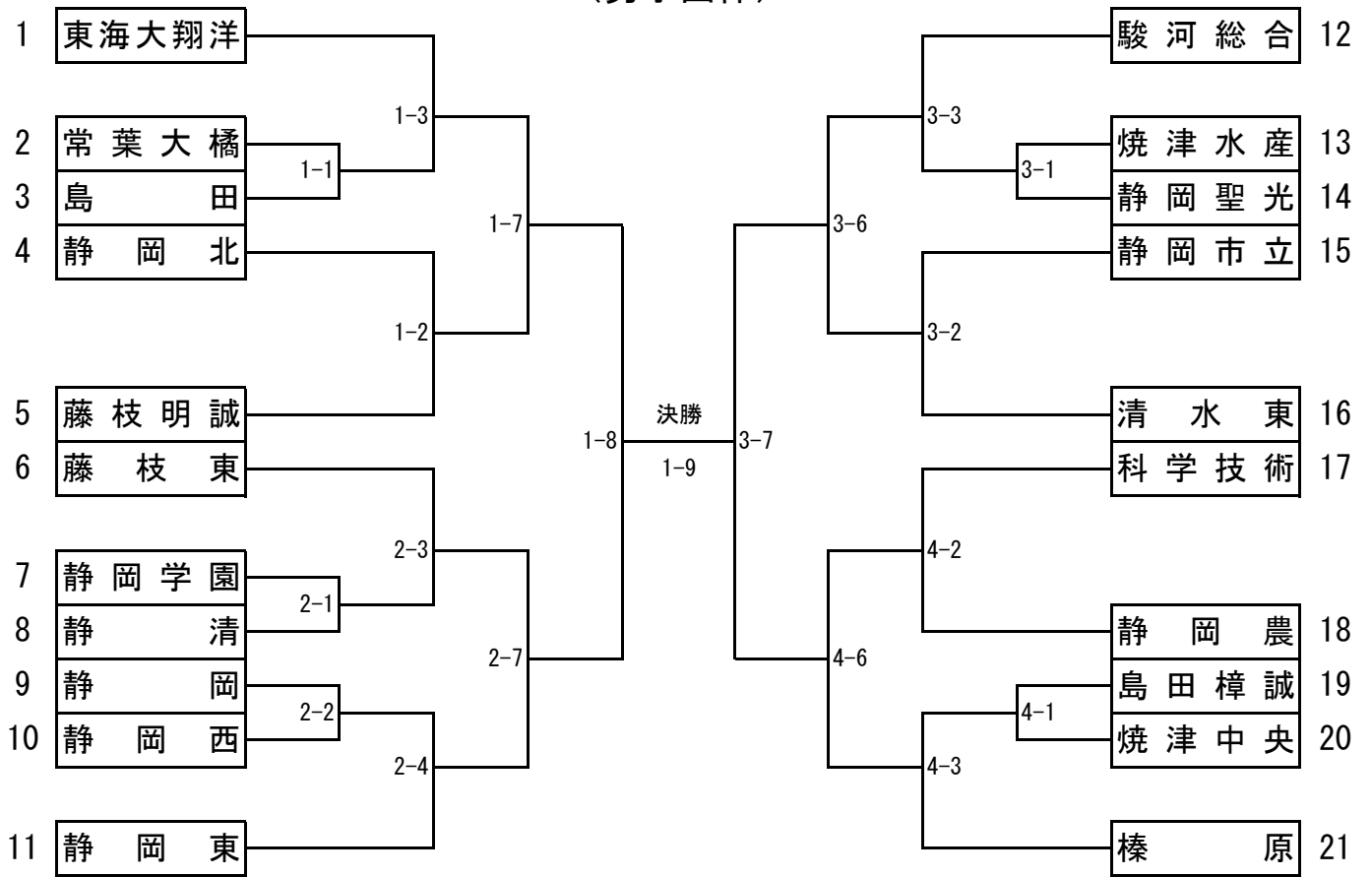

令和4年度 静岡県高校総体剣道競技中部地区予選 (女子団体)

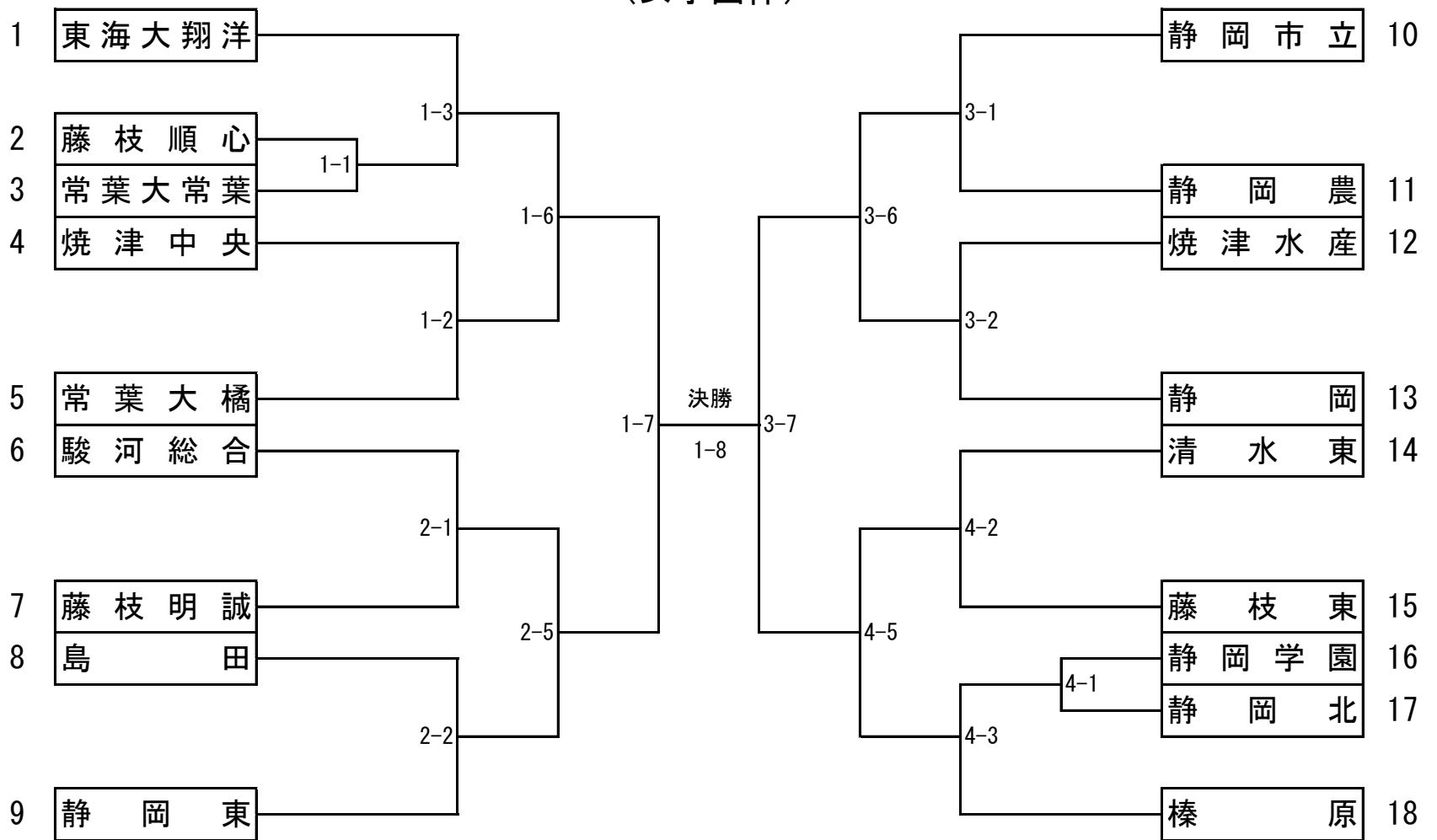

9・10位 決定戦

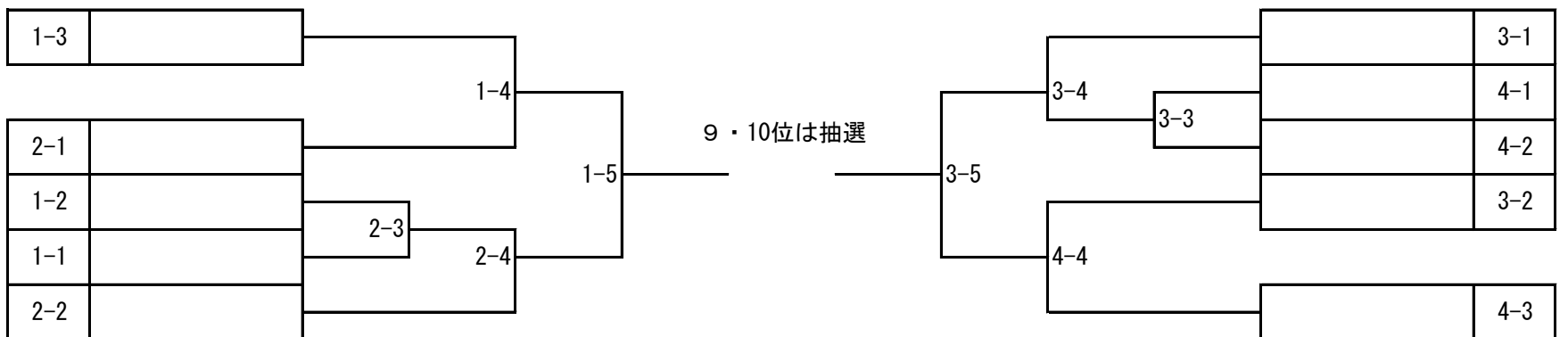

5~8位 決定戦



決勝戦

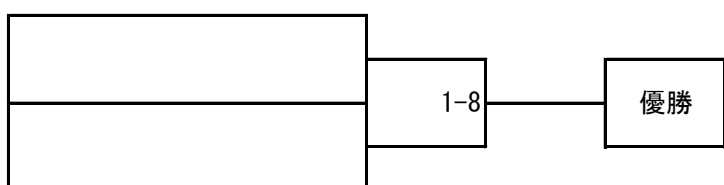

3位決定戦

